



---

[www.serverlift.com](http://www.serverlift.com)

***SL-350X***<sup>TM</sup>

---

**Manual ServerLIFT**

# **Operator's Manual**

Serial# SL-3X0 -

<b>Introduction</b>	<b>3</b>
Included with SL-350X™ ServerLIFT	3
Tools needed for adjustment	3
<b>Legend</b>	<b>4</b>
<b>Set Up</b>	<b>6</b>
Before you begin	6
Pre-operation Inspection	6
Function Tests	6
<b>Instructions</b>	<b>10</b>
Before operating the ServerLIFT	10
Stabilizer Brake Operation	11
Applying Load To The Platform	12
Front Caster Swivel Lock Operation	12
Safety Directions	13
<b>Accessories</b>	<b>14</b>
LE-500X™ Lift Extension	14
RL-500™ Platform Riser	18
<b>Maintenance</b>	<b>20</b>
Schedule of Maintenance	20
Stabilizer Brake Adjustment	21
Stabilizer Brake Boot Replacement	22
Winch and Cable Inspection	22
Pulley Inspection	23
<b>Specifications</b>	<b>24</b>
Features	24
Dimensions and Capacity	25
<b>Troubleshooting</b>	<b>26</b>
<b>Warranty</b>	<b>29</b>
<b>CE Declaration</b>	<b>31</b>

**ServerLIFT Corporation**  
821 N 2nd Street | Phoenix, AZ USA 85004  
(602) 254-1557



**Shipping/Receiving:**  
*shipping@serverlift.com*

**Service & Support:**  
*support@serverlift.com*

**Sales:**  
*sales@serverlift.com*

## ⚠ CAUTION:

Read and completely understand the contents of this Operator's Manual before operating the ServerLIFT. Failure to read, understand, and follow instructions in this manual may result in property damage and/or personal injury. If you do not understand any part of this manual or if you have any questions please contact ServerLIFT Service & Support.

**IMPORTANT:** Keep these instructions with ServerLIFT.

- Do not stand or ride on any part of the ServerLIFT.
- Never lift or move the ServerLIFT with a pallet truck, jack, or forklift. Use the pallet, ramp, and packaging originally received with the unit for transporting it.
- Keep hands, fingers and clothing clear of platform and mast when equipment is in motion.

**Never unwind the SL-350X™ ServerLIFT past the bottom of travel!**

## Included with SL-350X™ ServerLIFT

(1) SL-350X™

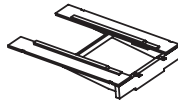
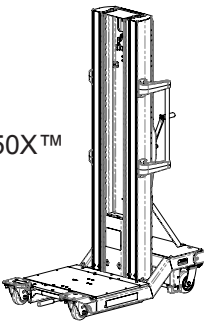

(1) Shipping Ramp

(1) Shipping Pallet  
*[includes retaining hardware]*

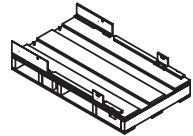

(1) Operator's Manual

(2) Adjustable Tie Down Strap

## Tools needed for adjustment

(1) 6mm hex wrench



(1) 3mm hex wrench

(1) 10mm or adjustable  
crescent wrench

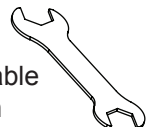

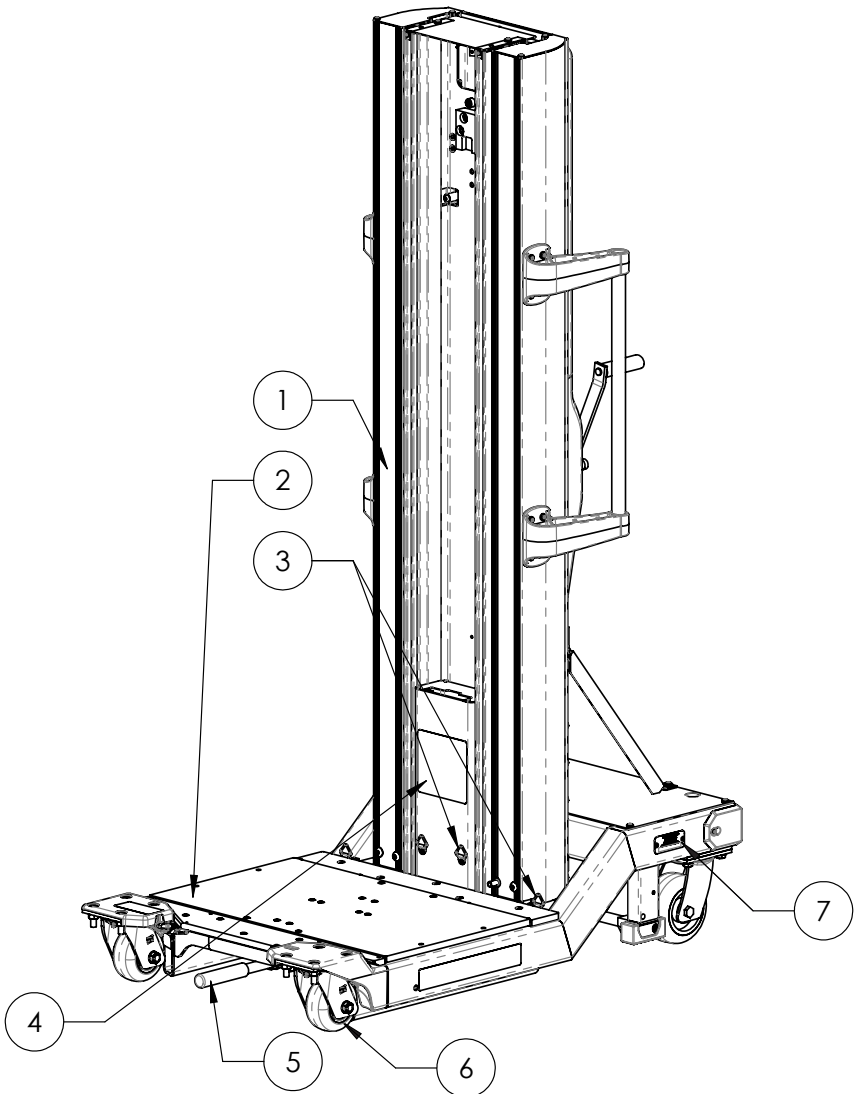

- |  |                            |
|--|----------------------------|
| 1. Vertical Mast                           | 4. Platform Mast           |
| 2. Equipment Platform and Easy-Glide Shelf | 5. Easy-Glide Shelf Handle |
| 3. Strap Hooks                             | 6. Casters - Free Swivel   |
|  | 7. Serial Number Plate     |

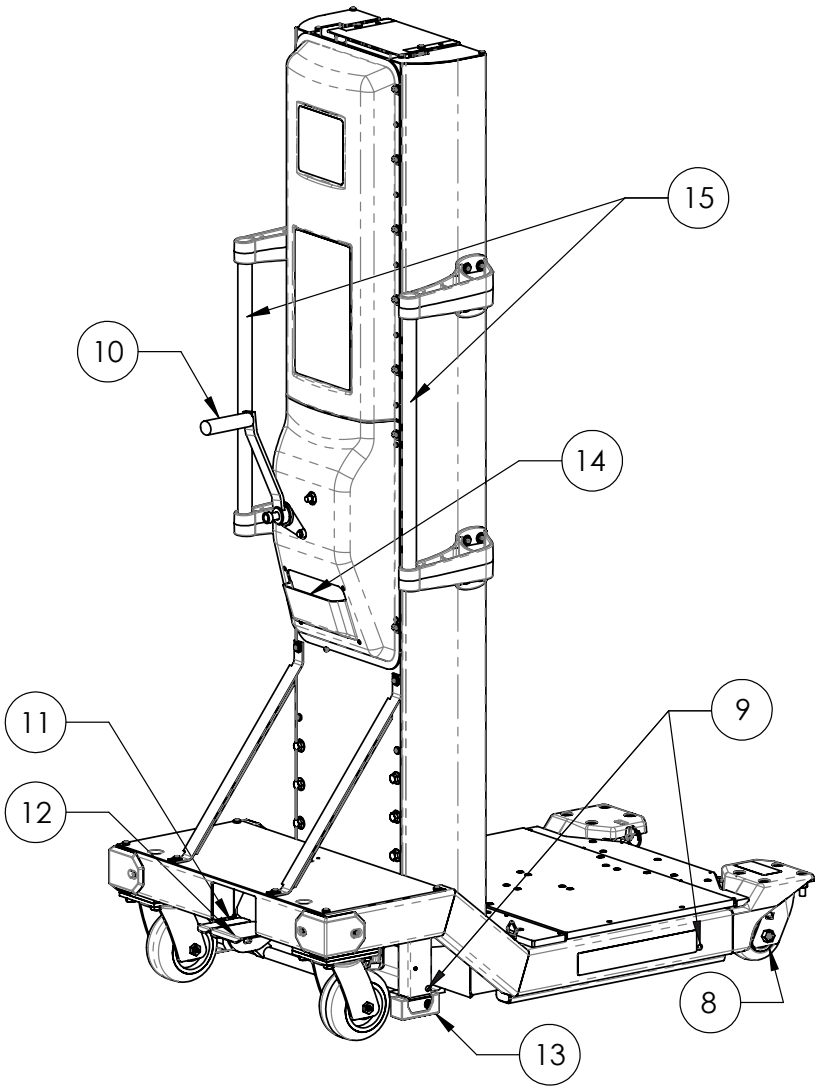

- |                                    |                              |
|------------------------------------|------------------------------|
| 8. Casters - Swivel/Lock           | 12. Stabilizer Brake Pedal   |
| 9. Pallet Bolt Holes               | 13. Stabilizer Brake Pad     |
| 10. Winch (Up/Down) Handle         | 14. Operator's Manual Sleeve |
| 11. Stabilizer Brake Release Pedal | 15. Handle Bars              |

## Before you begin

1. Read and understand the contents of this manual carefully.
2. Locate the serial number plate. Record unit serial number on front page of Operator's Manual for future reference.
3. Perform *Pre-operation Inspection*.
4. Perform *Function Tests*.

## Pre-operation Inspection

Check ServerLIFT for signs of damage. Fully document any damage with photos, location, and description. Promptly contact ServerLIFT Shipping or Service & Support if any damage is present.

## SAVE PALLET, RAMP, HARDWARE AND PACKING CARTON!

They are needed for moving the ServerLIFT to other locations.

## Function Tests

Function Tests are designed to discover malfunctions before ServerLIFT is used. Tests should be performed before normal operation. Before testing, select an area that is solid, level and free of obstructions.

⚠ **Note:** *After testing, if malfunctions are discovered, the unit must be removed from service. Repairs may only be made by or under the directions of a qualified service technician.*

## Stabilizer Brake Function Test

See **Stabilizer Brake Operation** (pg. 11) for additional details.

1. Press down red Stabilizer Brake Pedal until it locks in place. The Stabilizer Brake should remain in DOWN position.

2. Attempt to move ServerLIFT. It should move with force but resist motion. If it rolls easily, or Stabilizer Brake does not lock in DOWN position, adjust Stabilizer Brake (pg. 21).
- ⦿ **Note:** *If operating correctly, excessive force is not needed to fully depress Stabilizer Brake. If greater than average force is required, proceed immediately to Stabilizer Brake Adjustment, pg. 21.*
3. To release, press green release pedal and allow pedals to return to UP positions.
4. If correctly adjusted, proceed to next Function Test.

## **Winch Function Test**

1. Engage Stabilizer Brake.
2. Rotate Winch Handle **CLOCKWISE** to move Platform **UP**. Test full range of motion up and down. Platform will stop moving in fully extended and fully retracted positions. If Platform does not travel full range of motion consistently, contact ServerLIFT Service & Support.

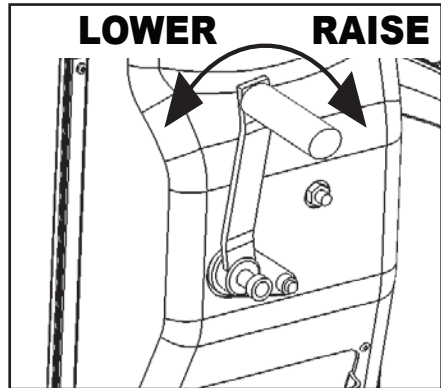

- ⦿ **Note:** *When raising Platform, Winch should produce a loud, sharp clicking noise. Load will remain in position when Winch Handle is released. When lowering Platform (unwinding Winch) no noise should be produced.*

*While load will remain in position when the handle is released, for extra safety it is recommended to turn Winch Handle clockwise until at least two clicks are heard.*

## ⚠ CAUTION

Platform Mast extends higher than Platform. When raising Platform, be aware of ceiling height, cable trays, sprinklers, lights, and other overhead obstructions.

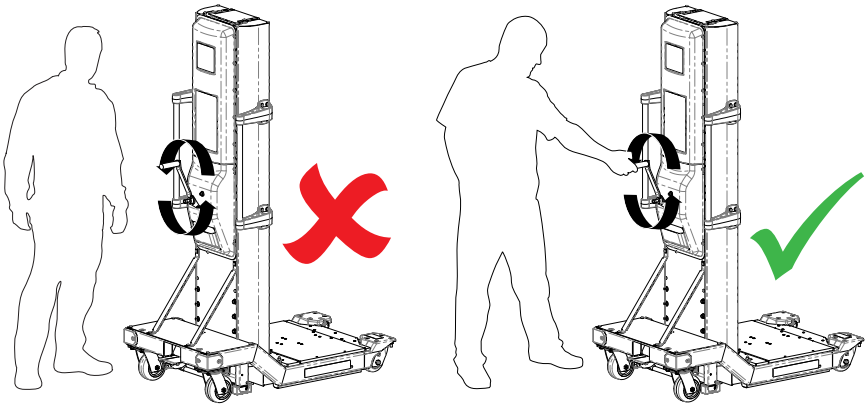

## ⚠ WARNING

- **DO NOT** turn Winch Handle past top or bottom of platform travel. Excessive unwinding will detach Handle and damage cable.
- **ALWAYS** hold Handle when lowering/ unwinding.
- Always satisfy yourself that Winch is holding load before releasing Winch Handle.
- **NEVER** allow Winch to unwind freely. Freewheeling will cause uneven cable wrapping around Winch Drum, damage cable, and may cause death or serious injury.
- Operate with hand power only. Do not operate ServerLIFT with a motor of any kind. If Winch Handle cannot be cranked easily with one hand, it is probably over-loaded.



## **Easy-Glide Shelf Function Test**

1. Engage Stabilizer Brake.
2. Raise Platform to a comfortable working height.
3. Pull Easy-Glide Shelf Handle out into extended position.

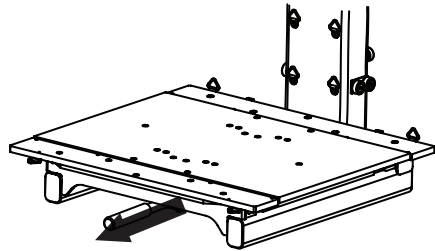

**Pull out handle**

4. In extended position, push down on handle to unlock and allow movement of Easy-Glide Shelf. Shelf will shift sideways up to 6" (15cm) in each direction. There are four incremental adjustment locations: two right of center, and two left of center.

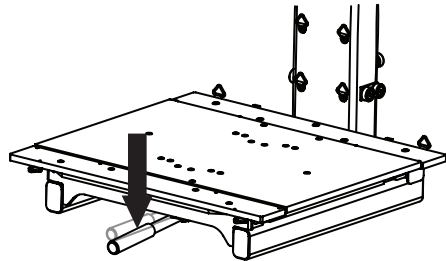

**Pull down handle**

5. Test full movement of Easy-Glide Shelf in both directions. If shelf does not travel entire range of motion consistently or does not lock at incremental adjustment locations, contact ServerLIFT Service & Support.

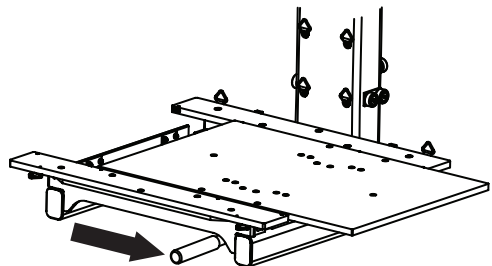



**Slide out shelf**

6. Return Shelf to neutral (center) position and lock in place. Push Easy-Glide Shelf Handle back into retracted position.
7. Lower Platform down. Release Stabilizer Brake.

## Before operating the ServerLIFT

1. Read and understand the operating steps and functions well.
2. Remove any objects or obstructions around or under ServerLIFT, or in travel area of Platform.
3. Make sure Stabilizer Brake engages and locks in place. Both Stabilizer Brake Pads must be installed and engage floor correctly (see **Stabilizer Brake Operation** on pg. 11).

## **SL-350X™ ServerLIFT Operating Steps**

1. Position ServerLIFT
-  2. Engage Stabilizer Brake
3. Adjust Platform to desired loading height
4. Load equipment onto Platform
5. Secure equipment using Adjustable Tie Down Straps (optional)
6. Lower Platform to lowest position
-  7. Release Stabilizer Brake
8. Move ServerLIFT to destination
-  9. Engage Stabilizer Brake
10. Raise platform to desired unloading height
11. Load equipment from Platform and Easy-Glide Shelf into rack
12. Lower Platform to lowest position
13. Release Stabilizer Brake

## Stabilizer Brake Operation

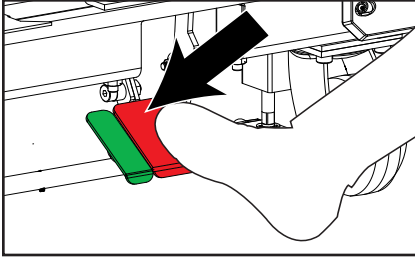

To engage Stabilizer Brake, depress red pedal until it locks in **DOWN** position. ServerLIFT should move with force but resist motion. If ServerLIFT moves freely, Stabilizer Brake is not functioning properly. See **Stabilizer Brake Adjustment** pg. 21.

⚠ **Note:** *If operating correctly, excessive force is not needed to fully depress Stabilizer Brake. If greater than average force is required, proceed immediately to Stabilizer Brake Adjustment, pg. 21.*

Once Stabilizer Brake is locked in **DOWN** position, ServerLIFT is stabilized and ready for use. Follow Operating Steps 3-6 or 10-12 (pg. 10).

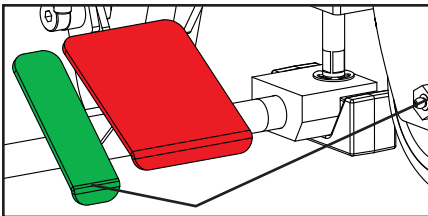
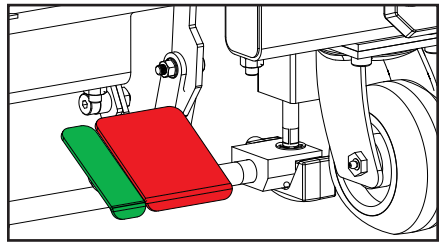

Press green release pedal and slowly pull foot back allowing both pedals to return to their original position.

### ⚠ **WARNING**

- Always engage Stabilizer Brake before raising, lowering, or sliding Easy-Glide Shelf
- Engage Stabilizer Brake whenever ServerLIFT is not in motion
- Do not move the ServerLIFT with Stabilizer Brake engaged

## Applying Load To The Platform

### **⚠ WARNING**

Never place more than 200lb (91kg) on edge of Platform Shelf

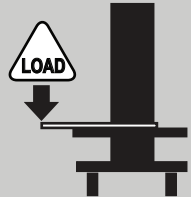
LOAD CAPACITY	
Maximum Load in Center of Platform	Maximum Load at Edge of Extended Platform
	
350 lbs / 159 kg	200 lbs / 91 kg

Center of Platform

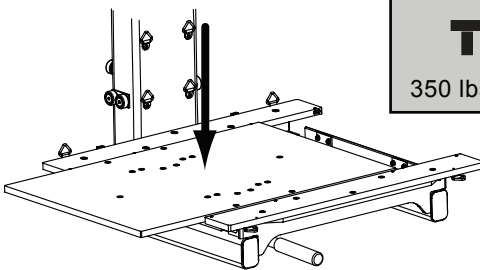

Edge of Platform

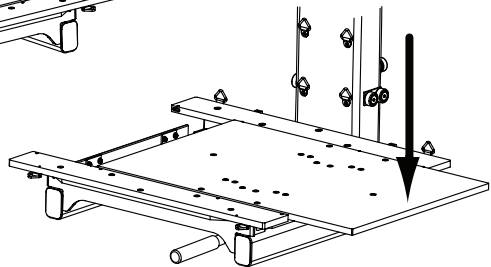

## Front Caster Swivel Lock Operation

### **UNLOCKED**

To unlock Front Caster, pull out ring and turn 90 degrees in either direction. Allow ring to align in vertical groove as shown.

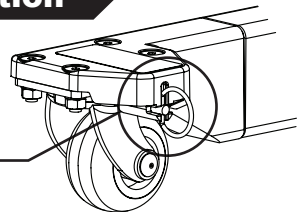

### **LOCKED**

To lock Front Caster, pull ring out and turn 90 degrees in either direction. Allow ring to align in horizontal groove as shown. Ensure caster is in line with base frame arm and pointing backward. An audible click indicates the lock is engaged.

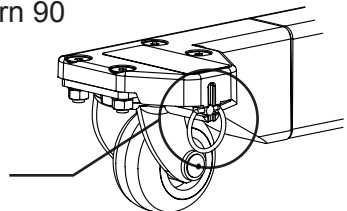

## Safety Directions

### Fall Hazards

- Do not use as a personnel lifting platform or step.
- Do not stand on any part of lift.
- Do not climb on mast.

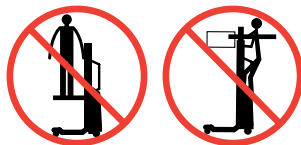

### Tip-over Hazards

- Do not lift load unless stabilizer is fully engaged.
- Do not move machine while platform is raised, except for minor positioning.
- Only raise load if properly centered on platform.
- Do not operate while under the influence of drugs or alcohol.
- Do not stand under overhanging load.
- Do not exceed rated load capacity.
- Do not stack loads.
- Do not support ladder against ServerLIFT.
- Do not use on uneven surface, incline, or decline.



### Collision Hazards

- Only lower load in areas clear of personnel and obstructions.
- Platform Mast extends higher than Platform. Be aware of ceiling height, cable trays, sprinklers, lights, and other overhead objects.

### Damaged Machine Hazard

- Do not operate a damaged or malfunctioning ServerLIFT.

### Improper Use Hazard

- Do not leave machine unattended with an elevated load.

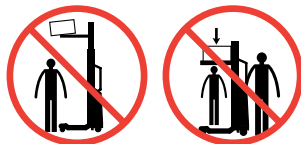

## LE-500X™ Lift Extension

The ServerLIFT LE-500X™ Lift Extension is an accessory that assists in lifting heavy IT equipment out of boxes and off of skids. It features a lightweight design that is capable of lifting up to 350lb (159kg) of equipment when used with the SL-350X™ ServerLIFT.

### **⚠ WARNING**

- Do not stand or ride on any part of Lift Extension.
- Do not exceed the maximum load of 350lb (159kg).
- Do not operate with a load that has a center of mass placed forward (away from the ServerLIFT) of indicated Lift Extension Load Center.

**NEVER USE THE LE-500X™ LIFT EXTENSION WITHOUT SWING ARM HOOK ENGAGED OVER LIP OF PLATFORM MAST**

### **Included with the LE-500X™ Lift Extension**

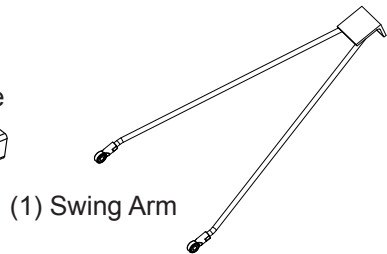
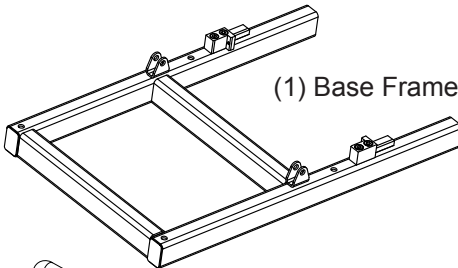

(4) Sling Hook

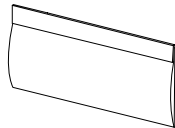

(1) Storage Bag

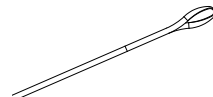

(2) Sling



(4) Rubber Foot

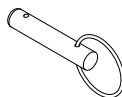

(2) Locking Pin

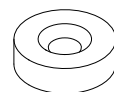

(4) Spacer

## Setting Up the LE-500X™ Lift Extension

ⓘ **Note:** Proper setup, installation, and use of this product is the sole responsibility of the installer.

1. Assemble Sling Hook into Spacer and insert completely through frame hole from the top as shown.
2. Screw Rubber Foot into bottom of Sling Hook. Repeat steps 1 and 2 in remaining three hook locations as shown.
3. Insert Swing Arm into both pivot brackets as shown.
4. Secure Spherical Rod Ends of Swing Arm to pivot brackets with Locking Pins.

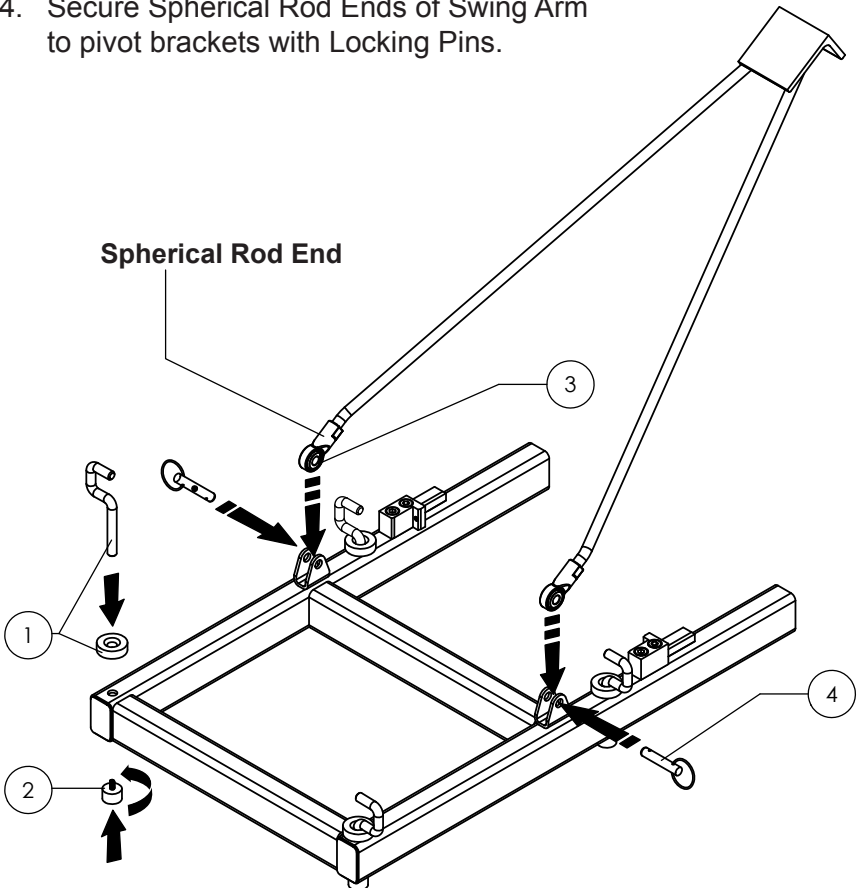

## Attaching Lift Extension to the ServerLIFT

1. Engage ServerLIFT Stabilizer Brake.
2. Raise Platform to a height of at least 1.5ft (0.5m) above Caster Wheel mounts.
3. With Swing Arm rotated towards closed end of Lift Extension Frame, insert Lift Extension into ServerLIFT Platform Frame as shown. Extension Catches should insert into Platform Frame tubes with top of Lift Extension Frame Arms resting against underside of the Platform Frame tubes.

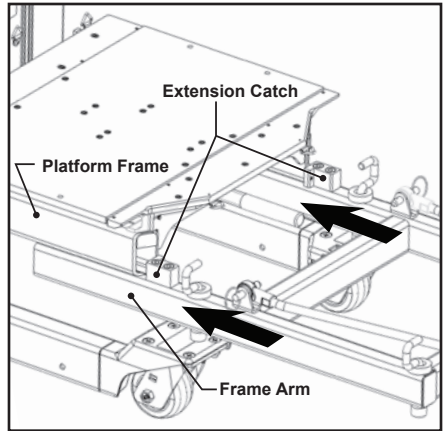

### **⚠ WARNING**

**Catches must be fully inserted into Platform Frame**

4. Rotate Swing Arm until its hook engages over the Platform Mast top lip.

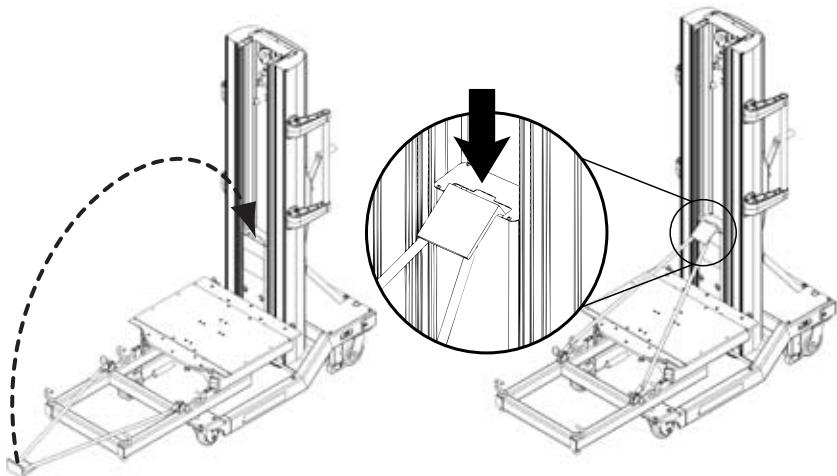



## **⚠ DANGER**

**Swing Arm MUST be engaged with Platform Mast before use. Using Lift Extension without Swing Arm engaged may cause death or serious injury.**

### **Adjusting the Swing Arm**

Adjustments may be necessary to ensure proper engagement.

If Swing Arm Hook goes too far over lip of Platform Mast, it is over-engaged. To adjust Swing Arm based on over-engagement:

1. Engage ServerLIFT Stabilizer Brake.
2. Raise Platform to a height of at least 1.5ft (0.5m) above Caster Wheel mounts.
3. Use a 3mm hex wrench to screw each Adjustment Screw equally inward (toward Platform) to create separation between Catches and Platform Frame. This increases engagement of Swing Arm Hook.

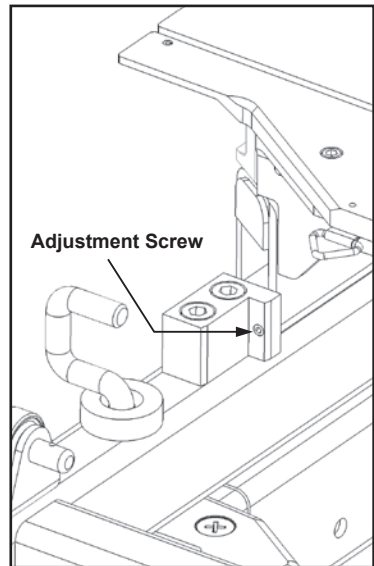

If Swing Arm Hook does not go easily over lip of Platform Mast, it is under-engaged. To adjust based on under-engagement:

1. Ensure that Adjustment Screws are completely loosened.
2. Make sure Lift Extension is fully inserted into Platform Frame. Front surface of Catches should touch Platform Frame.
3. If Swing Arm Hook is still under-engaged, remove Lift Extension from ServerLIFT.

4. Remove Locking Pins, and disassemble Swing Arm from Lift Extension.
5. Lengthen Swing Arm by rotating each Spherical Rod End counterclockwise (with Rod Ends facing you and Hook end facing away from you) one full turn (360 degrees).
6. Reassemble Swing Arm and Lift Extension with Locking Pins.
7. Re-attach Lift Extension to ServerLIFT and engage Swing Arm. If it is still under-engaged, repeat steps 3-7.

## RL-500™ Platform Riser

The ServerLIFT RL-500™ Platform Riser accessory enables users to install servers at the top of any rack in areas where equipment positioning is a challenge. These situations include:

- Low ceilings clearance or obstructions
- Cold and hot aisle containment rooms
- Ten foot (3 meter) tall racks
- Drop in rails

The ServerLIFT RL-500™ Platform Riser features a lightweight yet rugged design, and is compatible with SL500, SL-500X™, and SL-350X™ ServerLIFTS.

### **WARNING**

- Do not stand or ride on any part of Platform Riser.
- Do not exceed the maximum load of 350lb (159kg).
- Do not use together with LE-500X™ Lift Extension.
- No corner load.

**SECURE PLATFORM RISER TO SERVERLIFT SHELF IN ALL FOUR LOCATIONS (WITH PROVIDED HARDWARE ONLY) PRIOR TO USE**

## Included with the RL-500™ Platform Riser

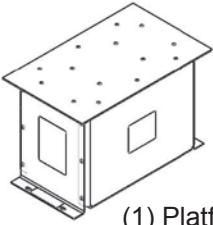

(1) Platform Riser

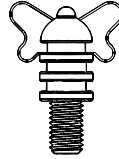

(4) Thumbscrew

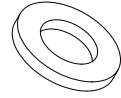

(4) Washer

## Attaching Platform Riser to the ServerLIFT

1. Engage ServerLIFT Stabilizer Brake.
2. Place Platform Riser onto ServerLIFT Easy-Glide Shelf. Line up slotted holes in bottom flanges of Platform Riser with threaded holes on ServerLIFT Easy-Glide Shelf.
3. Secure Platform Riser to Shelf with Thumbscrews and Washers in all four locations as shown.

### **⚠ WARNING**

**Platform Riser must be secured in all four locations**

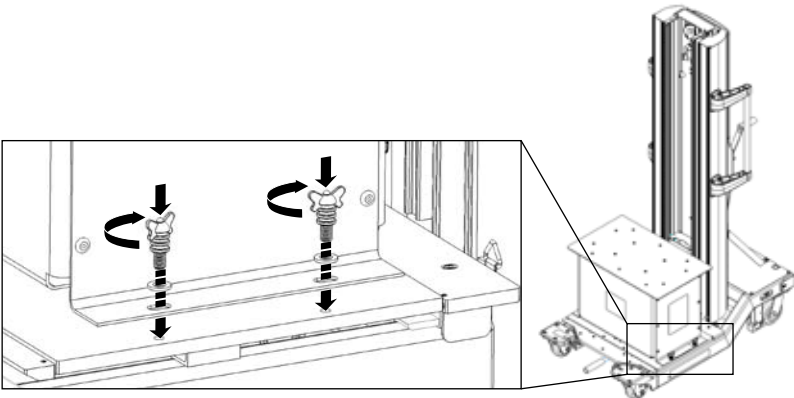

- ⓘ **Note:** Platform Riser should be removed and set aside when not in use. Four holes on Platform Riser top plate are provided for convenient storage of Thumbscrews and Washers when not in use.

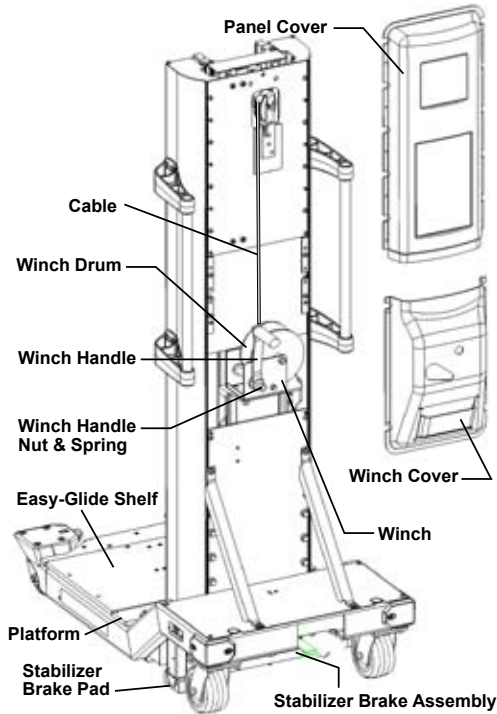

## Schedule of Maintenance

Activity	Required Frequency
Adjust Stabilizer Brake	As needed
Replace Stabilizer Brake Pads	As needed
Grease gears, drum shaft, crank shaft bearings, & handle threads	As needed or every 12 months
Inspect Winch and Cable	Every 12 months
Inspect Pulleys	Every 12 months

**Note:** Units covered under optional Extended Warranty and Service contracts have all above maintenance checks performed as part of ServerLIFT's warranty service visit.

## Stabilizer Brake Adjustment

➔ **Note:** Adjustments should only be made if ServerLIFT moves freely or very easily after Stabilizer Brake is engaged.

1. Move ServerLIFT to a smooth, flat surface.
2. Press red Stabilizer Brake Pedal until it locks.

➔ **Note:** If operating correctly, excessive force not needed to fully depress Stabilizer Brake. If excessive force is required to lock it, **DO NOT LOCK IT** - keep red pedal partially depressed and proceed to next step.

3. Loosen Brake Pad Set Screw using a 6mm hex wrench.

Stabilizer Brake Adjustment Rod  
Stabilizer Brake Pad  
Set Screw

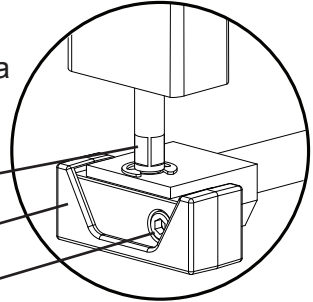

➔ **Note:** To raise Stabilizer, turn adjustment rod clockwise; to lower Stabilizer, turn adjustment rod counter-clockwise.

4. For optimal adjustment, turn Stabilizer Adjustment Rod using a 10mm or adjustable crescent wrench until Stabilizer Brake Pad is flush with floor, then rotate an additional 1/2 turn.
5. Re-tighten set screw.

### ⚠ **WARNING:**

- Over-adjustment prevents locking while under-adjustment prevents Stabilizer Brake from engaging floor and the ServerLIFT from functioning correctly.
- **NEVER** operate or leave unattended without fully engaging and locking Stabilizer Brake.
- **ALWAYS** disengage (unlock) Stabilizer Brake before moving or rolling ServerLIFT.

## Stabilizer Brake Boot Replacement

1. Pull top corners of old boot out and down to remove from Stabilizer Brake Pad.
2. Press new boot on until it snaps in to place.

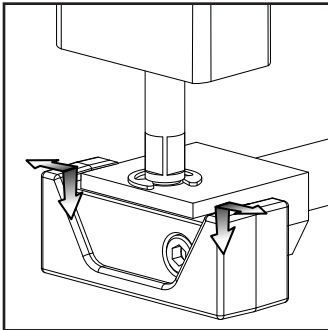

Removal

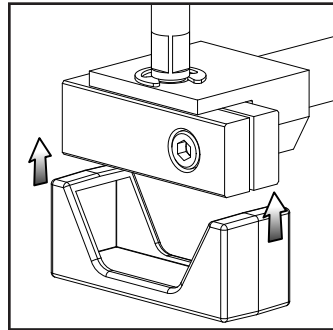

Installation

## Winch and Cable Inspection

Remove Panel Cover and Winch Cover.

### Winch Inspection

1. Fully cycle Platform up and down while inspecting Winch components.
2. When inspecting Winch, look for:
  - **Damaged or severely worn parts**
  - **Smooth engagement of gears**
  - **Clutch disk damage or wear**
  - **Loose fasteners or components**
  - **Debris or foreign objects interfering with operation**
  - **Missing Handle Nut and/or Spring**

Discontinue use of ServerLIFT if any Winch damage is discovered upon inspection, and contact ServerLIFT Service & Support immediately. Do not attempt to repair or change Winch.

## **Cable Inspection**

1. Fully lower platform and inspect front upper Cable section.
2. Fully cycle Platform up and down while inspecting section of Cable winding onto Winch.
3. When inspecting Cable, look for:
  - **Wear or Corrosion**
  - **Broken wires or cut strands**
  - **Uneven spooling of Cable on Winch Drum**
  - **Distortion, kinking, uneven strands, crushed parts, uneven cable diameter, or strands coming off**

Discontinue use of ServerLIFT if any Cable damage is discovered upon inspection, and contact ServerLIFT Service & Support immediately. Do not attempt to repair or change Cable.

## **Pulley Inspection**

When inspecting pulleys, look for cracks, extreme wear, loose connections, and bent or damaged pulley guards.

➡ **Note: Bent or damaged pulley guards WILL interfere with cable operation. DO NOT attempt to operate with damaged pulleys.**

1. Remove Panel Cover. Inspect Back Upper Pulley.
2. From front of the machine, inspect Front Upper Pulley.
3. Inspect Lower Pulley from undercarriage of the ServerLIFT.

➡ **Note: Lower Pulley is only visible from undercarriage when Platform is completely lowered.**

If inspection reveals any pulley irregularities or damage, discontinue use of ServerLIFT and contact ServerLIFT Service & Support immediately.

## Features

### **Compact Design**

- Slim 24" (61cm) base easily navigates narrow aisles
- 4 oversized swivel casters for tight maneuvering and protection of raised floor tiles
- Swivel locks in front engage when straight tracking is required
- Fits through standard doorways
- Ideal for cold aisle containment rooms
- Overall heavy duty steel and aluminum construction
- Reusable packaging included for location transfers

### **Heavy Duty Platform**

- Does not deflect or sag even under full (350lb / 159kg) load
- Precise equipment alignment
- Included tie-down straps secure equipment during moves

### **Side-Loading Usability**

- Load equipment while parallel to the rack
- Eliminates any obstruction of operator's view
- Easy alignment facing the rack

### **Easy-Glide Shelf**

- 6" (15.25cm) left or right lateral movement for supported loading
- Fits into standard 19" (48.25cm) racks
- Pull-out/retractable handle
- Seamless install from the platform into the rails

### **Telescoping Mast**

- Lifts 350lb (159kg) to the top of a rack (8' / 2.45m)
- Quickly raises equipment to the top in under 1 minute
- Enables safe use in contained and open environments without any modifications or adjustments

### **Locking Stabilizing Brake System**

- Restricts unit from moving during installation
- Increases side-to-side stability



## Dimensions and Capacity

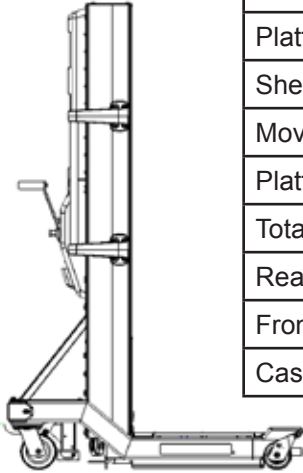

Working Dimensions	US	Metric
Platform Height, Extended	8.0'	2.44m
Platform Height, Lowered	5.3"	13.5cm
Shelf Movement per side	6.0"	15.2cm
Movable Platform Width	14.6"	36.8cm
Platform Length	24"	61.0cm
Total Platform Width	21"	53.0cm
Rear Caster Wheel Diameter	5"	12.7cm
Front Caster Wheel Diameter	4"	10.2cm
Caster Wheel Width	2"	5.08cm

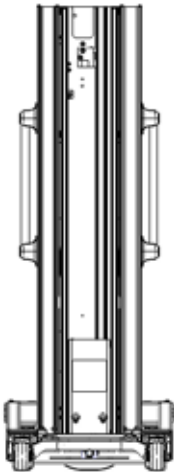

Product Dimensions	US	Metric
Unit Height (Lowered)	5' 8"	1.73m
Unit Height (Raised)	9' 2.8"	2.81m
Length	3' 8"	1.12m
Width	2' 0.5"	0.62m

Capacity and Weight	US	Metric
Capacity at Platform Center	350lb	159kg
Capacity at Platform Edge	200lb	91kg
Total Unit Weight	333lb	151kg
Rated Cable Failure Load	4000lb	1814kg

Specifications subject to change without notice

## Stabilizer Brake Does Not Work

Possible Cause	Solution
Stabilizer Brake needs adjustment.	Adjust Stabilizer Brake (see pg. 21)
Operating on uneven floor.	Make sure unit is on even floor. Do not operate unit on uneven floor.
Stabilizer Brake latch not engaging/locking.	Check undercarriage of unit to see if Stabilizer Brake latch is engaging. If it does not AND Stabilizer has been correctly adjusted, contact ServerLIFT Service & Support.

## Front Caster Wheels Do Not Lock

Possible Cause	Solution
Locking pin not engaging with caster groove.	Make sure there are no obstructions between pin and groove. Adjust caster wheel until engagement occurs. Detailed directions for this adjustment available from ServerLIFT Service & Support.
Caster groove or locking pin worn or damaged.	Replace worn or damaged hardware.

## Easy-Glide Shelf Does Not Side Shift

Possible Cause	Solution
Handle must be extended out and pressed down.	Extend handle and press down. Attempt to shift Shelf sideways.
Path of shelf is obstructed.	Locate and remove obstruction(s).
Locking mechanism is damaged.	Check under Platform for damaged part(s) and repair/replace where needed.

## Shelf Handle Pulls Out Or Won't Lock

Possible Cause	Solution
Handle retaining ring is missing or damaged.	Replace retaining ring. Contact ServerLIFT Service & Support for replacement part.

## ServerLIFT Does Not Move/Roll

Possible Cause	Solution
Stabilizer Brake may be engaged.	Disengage Stabilizer Brake.
Obstruction with caster wheel.	Remove obstruction.
One or more caster wheels damaged.	Replace damaged hardware.

## ServerLIFT Does Not Swivel/Turn

Possible Cause	Solution
Front Swivel Lock(s) engaged.	Disengage Swivel Lock(s).
Obstruction with caster wheel.	Remove obstruction.
One or more caster wheels damaged.	Replace damaged hardware.

## Platform Travel "Choppy" or "Jumpy"

Possible Cause	Solution
Handle was unwound excessively, causing Cable to loosen and re-spool unevenly.	Remove Winch Cover and completely unwind Cable. Re-wind Cable onto Winch Drum while holding tension on Cable and ensuring neat and even spooling.

## Platform Lowers But Does Not Raise

Possible Cause	Solution
Handle was unwound excessively.	Wind Winch by rotating Handle CLOCKWISE until at least two clicks are heard.
Handle retaining Nut and/ or Spring loose or missing.	Tighten/replace Nut and/or Spring.

## Platform Raises But Does Not Lower

Possible Cause	Solution
Platform is obstructed.	Remove obstruction from below Platform.

## Load Not Held When Handle Released

Possible Cause	Solution
Handle was unwound excessively.	Wind Winch by rotating Handle CLOCKWISE until at least two clicks are heard.
Handle retaining Nut and/or Spring loose or missing.	Tighten/replace Nut and/or Spring.
Clutch is worn or damaged.	Replace clutch. Contact ServerLIFT Service & Support for assistance.

## Winch "Freewheels" When Unwinding

Possible Cause	Solution
Handle was unwound excessively, causing Cable to loosen an re-spool unevenly.	Remove Winch Cover and completely unwind Cable. Re-wind Cable onto Winch Drum while holding tension on Cable and ensuring neat and even spooling.
Handle retaining Nut and/or Spring loose or missing.	Tighten/replace Nut and/or Spring.
Clutch is worn or damaged.	Replace clutch. Contact ServerLIFT Service & Support for assistance.
Burrs / damage on Winch Handle threads.	Clean threads or replace Winch Handle.

## **SL-350X™ SERVERLIFT LIMITED WARRANTY**

### **LIMITED WARRANTY COVERAGE**

The limited warranty covers defects in materials and workmanship of the ServerLIFT SL-350X™ (collectively “Equipment”). The warranty is not transferable. The warranty applies only to the original end-user owner of the Equipment unless prior written notice is received by and approval given by ServerLIFT.

For the Warranty Periods listed below, ServerLIFT Corporation (henceforth “ServerLIFT”) warrants that the Equipment:

1. Will be free from defects in materials and workmanship.
2. Will perform substantially in accordance with ServerLIFT’s published specifications.

ServerLIFT will repair or replace any parts that are in-warranty in accordance with the Limited Warranty Return & Repair Policy listed below.

### **LIMITED WARRANTY PERIODS**

The Warranty Period is one year from the day of delivery, except for structural components which are warrantied for 10 years from the day of delivery.

### **LIMITED WARRANTY EXCLUSIONS**

The warranty is void if:

- The applicable Warranty Period has expired;
- The Equipment has missing or altered serial numbers; or
- The Equipment has been repaired or modified by an agent not authorized by ServerLIFT.

The warranty specifically excludes damage to Equipment, including but not limited to:

- Damage incurred during shipment (other than shipping with a ServerLIFT contracted carrier);
- Damage caused by impact with other objects, drops or falls, including external case cracks, dented or punctured case, broken latches, torn covers, broken doors, or physical breakaway of internal components;
- Damage caused by intrusion of foreign matter into the Equipment;
- Damage to Equipment caused by environmental corrosion;
- Damage caused by improper maintenance;
- Damage caused by use of apurtenances not supplied by ServerLIFT or failures which result from alterations, modifications or foreign objects;
- Damage caused by the use of the Equipment for purposes other than for which it was designed;
- Damage caused by other abuse, misuse, neglect, accident, negligence, mishandling or misapplication; and
- Damage attributable to acts of G-d.

### **LIMITED WARRANTY RETURN & REPAIR POLICY**

For warranty assistance call ServerLIFT Corporation at 1-602-254-1557 between 9:00 a.m. and 5:00 p.m. Mountain Standard Time, Monday through Friday (excluding observed holidays), e-mail [support@serverlift.com](mailto:support@serverlift.com) or visit <http://serverlift.com/support/>.

Equipment that fails to comply with this warranty shall, at ServerLIFT's sole discretion, be repaired or exchanged for an equivalent replacement. You are responsible for returning the non-conforming Equipment, properly packaged, to ServerLIFT during the Warranty Period. ServerLIFT will pay return shipping costs of Equipment serviced under the Limited Warranty.

To obtain warranty service or to return Equipment, written notification must be made to ServerLIFT in advance via e-mail ([support@serverlift.com](mailto:support@serverlift.com)) or fax (1-602-254-1975) that must include the following information:

- Equipment serial number;
- Date of original Equipment receipt;
- Original ServerLIFT invoice and/or invoice number (proof of purchase);
- Contact information of the end-user and location of Equipment; and
- Description of the problem and/or desired service action.

In the event of a return or repair that is determined to occur at ServerLIFT's facilities, you will be issued a Warranty Repair Authorization (WRA) number and shipping instructions. Otherwise, ServerLIFT will arrange onsite service based on a mutually convenient schedule.

Equipment returned with a void warranty and/or without prior notification to and approval from ServerLIFT may be repaired and/or shipped back to the end-user at their expense.

If it is determined that the problem is not covered under warranty, you will be contacted with service alternatives available on a time and materials basis. You will also be responsible for all applicable shipping costs.

## WARRANTY LIMITATIONS

IN NO EVENT SHALL SERVERLIFT BE LIABLE, WHETHER IN CONTRACT, NEGLIGENCE, TORT, OR ON ANY OTHER BASIS, FOR COVER OR FOR INCIDENTAL, CONSEQUENTIAL OR EXEMPLARY DAMAGES ARISING OUT OF OR IN CONNECTION WITH THE SALE, SERVICES, MAINTENANCE, USE, PERFORMANCE, FAILURE, OR INTERRUPTION IN THE OPERATION OF EQUIPMENT, SERVICES, HARDWARE OR SOFTWARE, EVEN IF SERVERLIFT IS ADVISED OF THE POSSIBILITY OF SUCH DAMAGES. THE WARRANTY IS IN LIEU OF ALL OTHER WARRANTIES, WHETHER EXPRESS, IMPLIED OR STATUTORY. SOME STATES DO NOT ALLOW LIMITATIONS ON IMPLIED WARRANTIES SO THIS LIMITATION MAY NOT APPLY TO YOU.

This warranty and performance hereunder shall be governed by and construed in accordance with the laws of the State of Arizona without reference to its choice of law principles.

## WARRANTY EXTENSIONS AND SERVICE CONTRACTS

Extended warranty periods and service contracts are available to suit your specific needs. To learn more about these optional service programs contact ServerLIFT sales via e-mail ([sales@serverlift.com](mailto:sales@serverlift.com)) anytime or by phone (1-602-254-1557) 9:00 a.m. to 5:00 p.m. Mountain Standard time, Monday through Friday (excluding observed holidays).



## **Declaration of Conformity**

**Manufacturer:** ServerLIFT Corporation  
821 N 2nd Street  
Phoenix, AZ 85004 USA  
602-254-1557  
www.serverlift.com

**Model numbers:** SL-350X™, SL-350XI™

**Type of equipment:** Server and IT equipment lifting machine

We declare that the product identified above meets the requirements of the following EU directives and standards for the purpose of CE compliance:

### **Directives/Standards:**

#### **Product Safety Directives**

**Machinery Directive 2006/42/EC**

Name: Mr. Raymond Zuckerman

Title: CEO

Date: 12/01/2011



---

[www.serverlift.com](http://www.serverlift.com)

---

© ServerLIFT Corporation 2012. All Rights Reserved.

SL, SL-500X, and SL-350X are trademarks of ServerLIFT Corporation